



Datos dimensionales (Pulgadas)

Dimensional data (Inches)

MEDIDA SIZE No.	A	E	L
16	±0.002 1.000	±0.015 1.626	±0.015 0.531
18	1.125	1.751	0.531
20	1.250	1.876	0.531
22	1.375	2.063	0.563
24	1.500	2.188	0.563
26	1.625	2.313	0.563
28	1.750	2.501	0.593
30	1.875	2.626	0.593
32	2.000	2.751	0.593
34	2.125	2.938	0.750
36	2.250	3.064	0.750
38	2.375	3.189	0.750
40	2.500	3.377	0.813

CONDICIONES DE OPERACIÓN

Velocidad: Hasta 10,000 R.P.M.

Presión: 200 PSI (14Kg/cm²)

*Temperatura: -57°C ~ 204°C

*Depende del material del elastómero

OPERATION CONDITIONS

Velocity: Up to 10,000 R.P.M.

Pressure: 200 PSI (14Kg/cm²)

*Temperature: -57°C ~ 204°C

*Depends on elastomer material

 **Partes Metálicas:** Acero inoxidable 316
Metal Parts: 316 Stainless Steel

 **Resorte:** Acero inoxidable 316
Spring: 316 Stainless Steel

 **Cara:** Carbón Grafito
Rotary Face: Graphite

 **Empaque:** NBR (Nitrilo®), FKM (Vitón®),
EPR (EPDM).
Bellow: NBR (Nitrile), FKM (Viton®),
EPR (EPDM).

 **Asiento:** Cerámica, Carburo de Silicio, Carburo de
Tungsteno, Acero Inoxidable, Ni-Resist.
Seat: Ceramic, Silicon Carbide, Tungsten Carbide,
Stainless Steel, Ni- Resist.

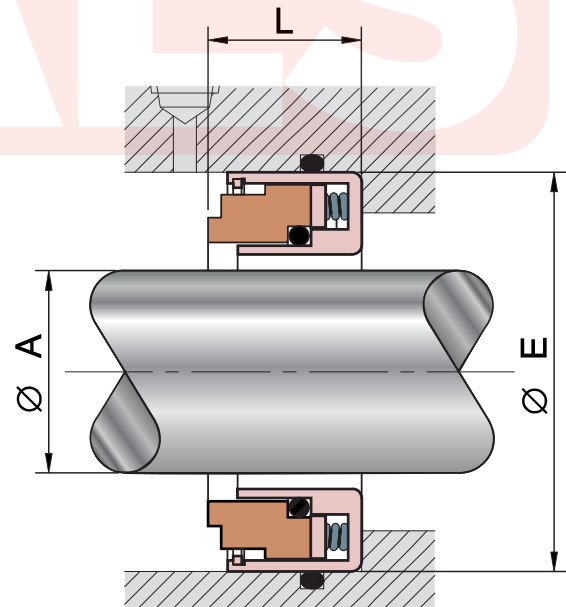

*Para parte rotativa consulte planta.